

TM 506001L Multi Purpose Chock DIN 81915 shape C

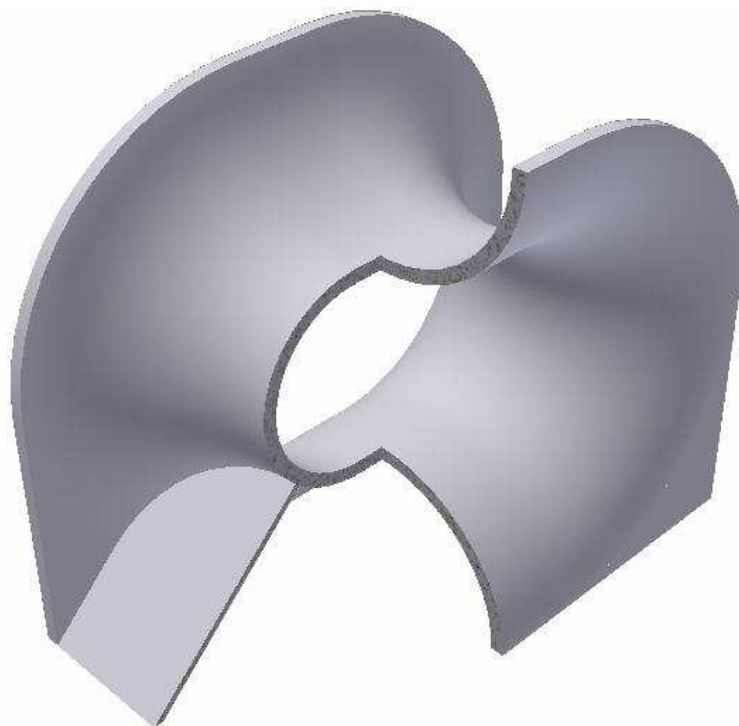
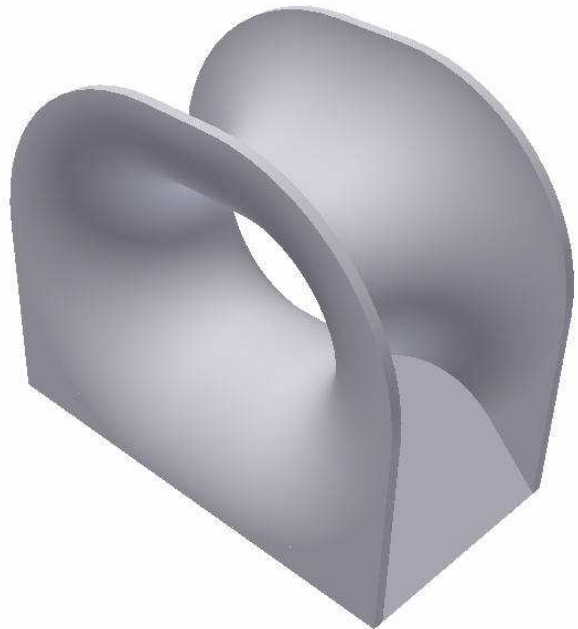
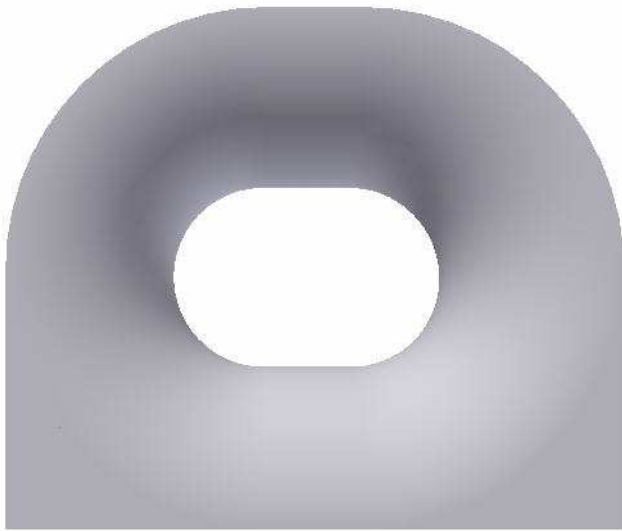

SECTION VIEW

See reverse for details ⇒

TECH-MARINE EQUIPMENT APS

ESRUMVEJ 421 • 3080 TIKØB • DENMARK

E-mail: Tech-Marine@Tech-Marine.dk • www.tech-marine.dk
Phone +45 4970 4395 • Fax + 45 4970 1769 • CVR 25 99 96 49

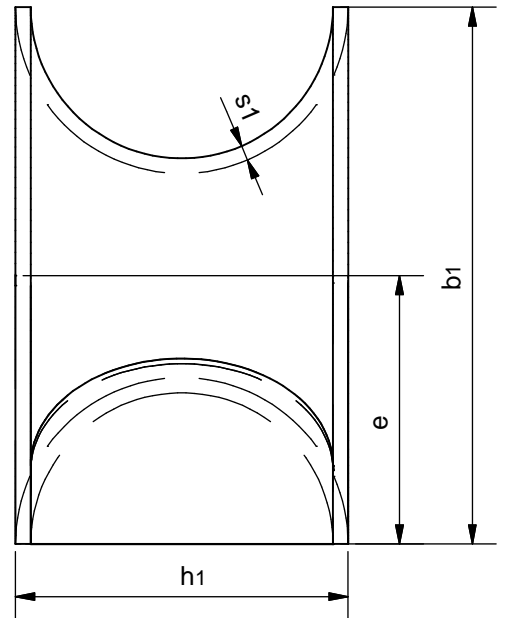
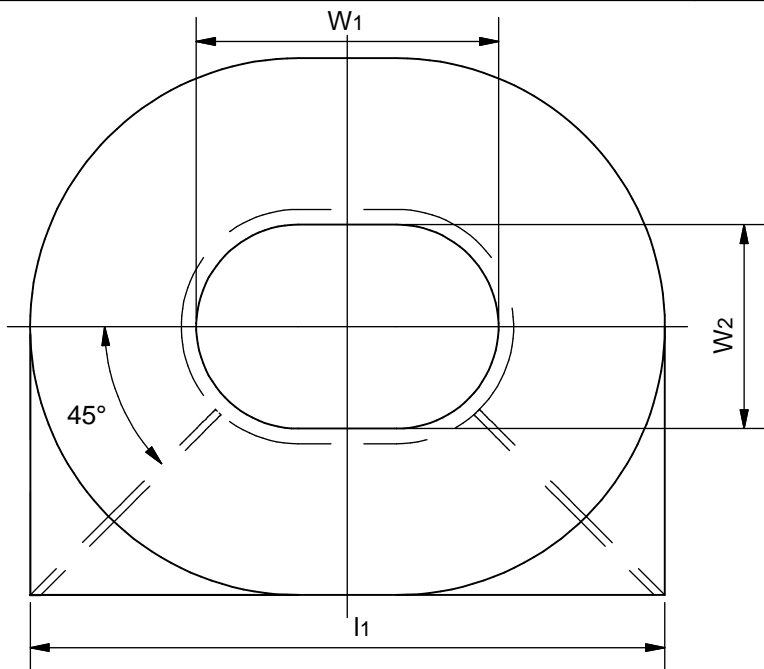

MULTI PURPOSE CHOCKS DIN 81915 shape C

DIN Type	TM Type	Rope load MBL (kN)	Measurements - mm							Weight kg
			w ₁	w ₂	l ₁	b ₁	h ₁	e	s ₁	
C1	125	98	125	90	285	250	160	125	10	19.5
C2	160	196	160	115	360	315	200	157.5	12	29
C3	200	294	200	140	450	390	250	195	14	48
C5	250	490	250	180	550	480	300	240	16	85
C8 *	320	785	320	225	680	585	360	292.5	18	136
C12 **	400	1177	400	270	840	710	440	355	20	211
C20	500	1962	500	320	1020	840	520	420	22	325
C32	600	3139	600	400	1300	1100	700	550	35	840

*) Comply with the Panama canal 2004 regulations for accompanying bitt for single chock load of 45,36 t (445 kN).

**) Comply with the:

Panama canal 2004 regulations for accompanying heavy bitt for double chock load of 64 t (628 kN).

Panama canal 2014 regulations Panamax Plus and New Panamax for accompanying heavy bitt for double chock load of 90 t (883 kN).

Material:

Cast steel (CS) - GS240 acc. to EN 10293 or equivalent
 or Grey Iron steel EN GJL-200 or equivalent
 or Stainless steel (SS) - G-X6CrNiMo 1810 acc. to EN 10283 or equivalent

Certification:

3.1 acc. to EN 10204:2004

Surface Treatment:

Cast steel & grey iron steel: Sa 2.5 + Hempel primer ZS 15890 grey.

Constructed in compliance with IMO Guidance, MSC/Circ. 1175 of 24 May 2005 and IACS UR A2 (Rev.3).

Design load 1.25 x MBL
 Allowable stresses 100/60 % of min yield point
 SWL = MBL

Suitable strengthening below deck by the yard.

Supporting hull structure and reinforcement beneath to be arranged by the yard to the satisfaction by the classification society.

Order: TM 506001L-Type-Material

Example: TM 506001L-C12-CS

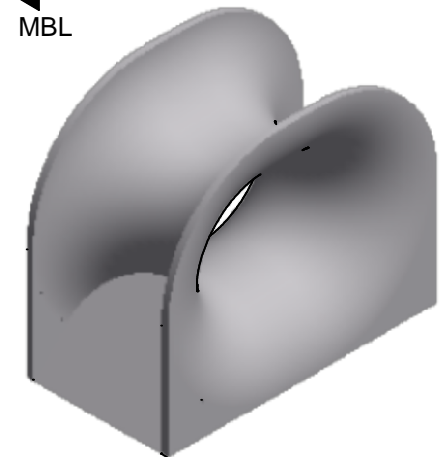
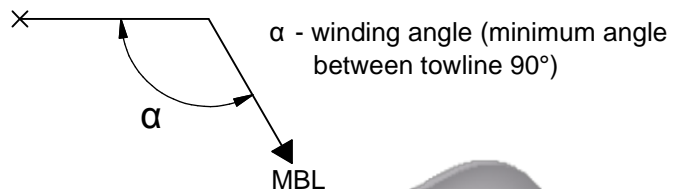

STANDARD

Tech-Marine Equipment ApS

Esrumvej 421 - DK 3080 Tikøb
 Phone +45 4970 4395 Fax. +45 4970 1769

Existing law protects TMs rights of possession to this drawing. The design or the drawing must not, without permission of TM be published, copied, reproduced, manufactured or exploited in any other way.

TM 506001L

Multi Purpose Chock DIN 81915 shape C

For deck mounting

Date	Checked	Revision
22-01-2016		F
Sheet	2 of 2	